



# Accutone 2

## AUDIOMETRIC BOOTHS

The 40a Classic Series **Single-Wall** (individual room) construction is a single or multiple occupancy room constructed of 4 inch thick modular panels, complete with carpeted vibration isolated floor, space-saver roof mounted ventilation, recessed electrical, **Noise-Lock®** doors and double glazed windows, audiometric jack panels acoustically matched and shipped ready for field installation.



**40a Classic Series**

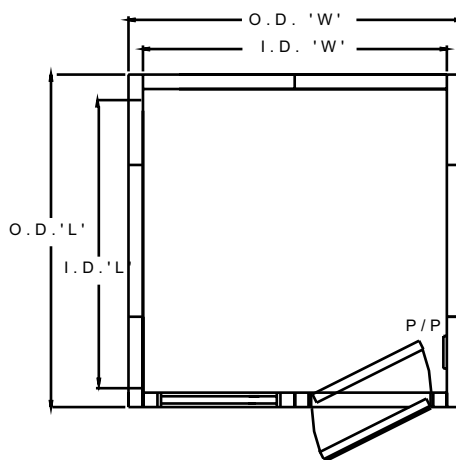

**Typical Plan**

| Model No. | Inside Dimension LxWxH |            |            | Outside Dimension LxWxH |            |            | Weight lbs |
|-----------|------------------------|------------|------------|-------------------------|------------|------------|------------|
|           | Ft x In.               | x Ft x In. | x Ft x In. | Ft x In.                | x Ft x In. | x Ft x In. |            |
| 40a-1     | 2 - 10                 | x 3 - 6    | x 6 - 6    | 3 - 6                   | x 4 - 2    | x 7 - 7    | 1071       |
| 40a-2     | 3 - 6                  | x 4 - 4    | x 6 - 6    | 4 - 2                   | x 5 - 0    | x 7 - 7    | 1398       |
| 40a2.5    | 3 - 6                  | x 6 - 2    | x 6 - 6    | 4 - 2                   | x 6 - 10   | x 7 - 7    | 1796       |
| 40a-3     | 3 - 6                  | x 6 - 8    | x 6 - 6    | 4 - 2                   | x 7 - 4    | x 7 - 7    | 1905       |
| 40a-4     | 4 - 8                  | x 7 - 0    | x 6 - 6    | 5 - 4                   | x 7 - 8    | x 7 - 7    | 2333       |
| 40a-5     | 6 - 2                  | x 6 - 2    | x 6 - 6    | 6 - 10                  | x 6 - 10   | x 7 - 7    | 2554       |
| 40a5.5    | 7 - 6                  | x 6 - 4    | x 6 - 6    | 8 - 2                   | x 7 - 0    | x 7 - 7    | 2986       |
| 40a-6     | 7 - 0                  | x 7 - 0    | x 6 - 6    | 7 - 8                   | x 7 - 8    | x 7 - 7    | 3045       |
| 40a-7     | 7 - 0                  | x 7 - 6    | x 6 - 6    | 7 - 8                   | x 8 - 2    | x 7 - 7    | 3198       |
| 40a-7.5   | 8 - 4                  | x 6 - 4    | x 6 - 6    | 9 - 0                   | x 7 - 0    | x 7 - 7    | 3251       |
| 40a-8     | 7 - 0                  | x 8 - 8    | x 6 - 6    | 7 - 8                   | x 9 - 4    | x 7 - 7    | 3553       |
| 40a-9     | 7 - 0                  | x 9 - 10   | x 6 - 6    | 7 - 8                   | x 10 - 6   | x 7 - 7    | 3909       |
| 40a-10    | 8 - 2                  | x 8 - 8    | x 6 - 6    | 8 - 10                  | x 9 - 4    | x 7 - 7    | 3958       |
| 40a-11    | 8 - 6                  | x 8 - 6    | x 6 - 6    | 9 - 2                   | x 9 - 2    | x 7 - 7    | 4016       |
| 40a-12    | 8 - 2                  | x 9 - 10   | x 6 - 6    | 8 - 10                  | x 10 - 6   | x 7 - 7    | 4348       |
| 40a-13    | 9 - 4                  | x 9 - 10   | x 6 - 6    | 10 - 0                  | x 10 - 6   | x 7 - 7    | 4786       |
| 40a13.5   | 11 - 2                 | x 8 - 8    | x 6 - 6    | 11 - 10                 | x 9 - 4    | x 7 - 7    | 4998       |
| 40a-14    | 9 - 10                 | x 10 - 6   | x 6 - 6    | 10 - 6                  | x 11 - 2   | x 7 - 7    | 5225       |

**INDUSTRIAL ACOUSTICS COMPANY, INC.**  
*IAC...is Making the World a Quieter Place!*

**40a Series Audiometric Booths**

**40a CLASSIC GENERAL NOTES:**

1. **TOTAL ESTIMATED DESIGN WEIGHT:** ( ) LBS.
2. **PANEL CONSTRUCTION:** NOISELOCK V (WALLS) AND NOISELOCK VI (CEILING)  
**INTERIOR SURFACES:** 22GA. GALVANIZED STUCCO EMBOSSED PERFORATED STEEL  
**EXTERIOR SURFACES:** 14GA. COLD ROLLED STUCCO EMBOSSED SOLID STEEL  
**FLOOR INTERIOR SURFACE:** 11GA. HOT ROLLED STEEL
3. **FINISH:** BAKED ACRYLIC ENAMEL PAINT  
**COLOR:** CHOICE OF (10) STANDARDS
4. **FLOOR COVERING:** INDUSTRIAL NYLON CARPET  
COLOR: (TO MATCH PAINT COLOR SELECTION)  
3/8" THICK UNDERLAYMENT AND 2 1/2" H BLACK COVE BASE MOLDING INCLUDED.
5. **DOOR:** (1) 2' X 9" WIDE X 6' - 11 1/2" HIGH CLEAR OPENING CAM-LIFT SPLIT-FRAME WITH PUSH PLATE AND PULL HANDLES.  
NOTE: DIMENSIONS LOCATING DOOR ARE SHOWN TO THE CLEAR OPENING
6. **WINDOW:** (1) 2'6" WIDE X 2'10" HIGH ALUMINUM FRAME DOUBLE GLAZED WITH 1/4" THICK LAMINATED SAFETY GLASS (WIDTH REDUCED ON SMALLER MODELS).
7. VIBRATION ISOLATOR RAILS TO BE PROVIDED BELOW FLOOR PANELS.
8. 2" MINIMUM CLEARANCE IS REQUIRED BETWEEN THE EXTERIOR OF TESTING BOOTH AND HOST FACILITY WALLS/CEILING.
9. **LARGEST PANEL SIZE:** ( ) WIDE X ( ) LONG X ( ) THICK. CUSTOMER TO ENSURE ADEQUATE SITE ACCESS.
10. **VENTILATION:** ( ) CFM SYSTEM COMPRISED OF INTEGRATED SPASAVER EXHAUST/INLET AIR CEILING SILENCER PANELS AND 120V, 60HZ, 14W FANS.
11. **ELECTRICAL:**
  - ( ) 120V RECESSED INCANDESCENT LIGHT FIXTURE
  - (2) 120V TOGGLE SWITCH FOR FANS AND LIGHTS
  - ( ) 120V DUPLEX RECEPTACLE
  - (1) 120V QUAD RECEPTACLE WITH POWER CORD (ROOF MOUNTED)
  - ( ) 120V J-BOX WITH POWER CORD (ROOF MOUNTED)
  - (1) JP-81 AUDIOMETRIC JACK PANEL COMPRISED OF:
    - (10) SWITHCRAFT #12B JACKS (INSIDE AND OUTSIDE)
    - (1) CINCH-JONES #S303-RP (INSIDE)/(1) CINCH JONES #P-303-RP (OUTSIDE)
    - (1) CINCH-JONES #S304-RP (INSIDE)/(1) CINCH JONES #P-304-RP (OUTSIDE)
    - (2) 1" I.D. GROMMETED OPENINGS (INSIDE AND OUTSIDE)
  - (LOT) BOXES, CONNECTORS, ETC. AS REQUIRED FOR COMPLETE INSTALLATION

**NOTE:**

  - A. CUSTOMER TO PROVIDE 110V, 60 HZ, 20 AMP POWER TO ROOF MOUNTED QUAD RECEPTACLE POWER CORD.
  - B. ALL ELECTRICAL IS WIRED PER 2002 NATIONAL ELECTRIC CODE
  - C. BOOTH IS FACTORY UL CERTIFIED AND LABELED
12. CUSTOMER TO PROVIDE A FINISHED FLOOR WHICH IS WITHIN +/- 1/4" OF LEVEL IN 10 NON-CUMULATIVE FEET.



**INDUSTRIAL ACOUSTICS COMPANY, INC.**

1160 commerce Ave, Bronx, New York 10462-5599 USA

Tel: 718-931-8000 / Fax: 718-863-1138

Website: [www.industrialacoustics.com](http://www.industrialacoustics.com)

E-mail: [info@industrialacoustics.com](mailto:info@industrialacoustics.com)

UK: Winchester, Hampshire Germany: Niederkruchten